

## Off-grid power supply – the future of district heating

ROBERT WIŚNIEWSKI<sup>a</sup>  
AGATA KANIA<sup>a</sup>  
WIESŁAW ZIMA<sup>b\*</sup>  
JAN TALER<sup>b</sup>

<sup>a</sup> Municipal Heat Supply Company, Jana Pawła II 188, 30-969 Kraków, Poland

<sup>b</sup> Cracow University of Technology, Department of Energy, Jana Pawła II 37, 31-864 Kraków, Poland

**Abstract** The paper presents the first off-grid system designed to supply electricity to the equipment mounted on components of the district heating network in district heating chambers. The proposed off-grid system is equipped, among other things, with a turbine and a generator intended for electricity production. On-grid power supply is a common way of providing electricity with strictly defined, known and verified operating parameters. For off-grid power supply, however, there are no documented testing results showing such parameters. This paper presents selected results of tests and measurements carried out during the operation of an off-grid supply system powering the equipment installed in a district heating chamber. The values of voltage obtained from a turbine-driven generator are analysed in detail. The analysis results can be used as the basis for further works aiming to optimize the off-grid system of electricity supply to devices installed in district heating chambers.

**Keywords:** District heating networks; District heating chamber and its modernization; Off-grid supply; Preliminary results of measurements

---

\*Corresponding Author. Email: [wieslaw.zima@pk.edu.pl](mailto:wieslaw.zima@pk.edu.pl)

## 1 Introduction

District heating has been faced with increasing goals and developments over the years [1]. This is largely the effect of increasing environmental requirements. The year 2014 marked the introduction of the 4th generation (4G) district heating [2], which is characterized by low supply temperatures (below 70°C) and digitization of district heating systems and nodes. The premise of the 4G district heating was to increase the efficiency of the district heating system and reduce the use of fossil fuels by integrating the network with low-temperature energy sources, such as geothermal sources, waste heat or solar collectors. Research projects on the 5th generation (5G) district heating networks were performed as early as in 2015 [3]. This generation assumes an additional cooling function and supply temperatures below 50°C. In addition, the 5G network will no longer have a central source but distributed sources. An example work with a focus on 5G networks is [4], dedicated to a 5G heating and cooling network for a residential district. It presents the design and a thermal and economic analysis of such a novel network.

The technical and economic aspects of the application of adsorption refrigeration devices to generate cool using hot water from a district heating network are the subject of [5]. The paper studies the operation of adsorption air-conditioning units co-operating with a dry cooler.

The future of district heating necessitates the introduction of new energy sources (such as renewable sources), as well as other modern solutions integrating and controlling parameters of transmitted thermal energy. The authors of [6] note that with the development of renewable energy sources and their application in district heating, district heating systems will become increasingly complex. They present the results of an analysis conducted, among others by means of artificial neural networks, and concerning optimization of the operation of combined heat and power (CHP) plants. A combined heat and power plant is also the subject of [7]. The paper emphasizes that for efficient operation of such a cogeneration system, it is necessary to provide short-term prediction of the heat demand within the horizon of the next day. A method of hourly forecasting of the heat load was proposed. The results of such off-season forecasting in a real district heating system are presented. Optimization issues are also addressed in [8]. Two mathematical models for the network operation optimization are presented. A detailed analysis is conducted of thermal energy storage in pipelines. Energy storage in district heating systems is also the focus

of [9], which presents the concept and implementation of droop control for a district heating network. The characteristics of the droop between the heated water temperature and the share of power in the thermal energy storage tank are developed for a district heating network using the analogy with the droop control in a direct current (DC) electrical network.

The development of district heating networks also requires the ability to simulate heat and pressure losses in the network. For this purpose, power companies use simulation software. Such software must include fast and efficient numerical methods that produce accurate and stable results [10].

In recent years, the topical issue has been smart district heating networks (SDHNs), in which the processes of the operation management (through data monitoring and gathering) and control are improved. In order to build, and first of all operate a SDHN, it is necessary to equip it with automatic devices and elements for monitoring and regulation. However, such devices need to be supplied with power, and the access of district heating network facilities (such as district heating chambers) to the power grid is often difficult. This involves the need to create an alternative source of power supply, referred to as off-grid power supply [11], characterized by no access to the power grid, but having its own local source of voltage. The literature survey indicates that so far off-grid power supply has not been analysed, let alone utilized to supply electricity to devices of district heating facilities, such as the district heating chamber. Consequently, there is no experience related to the selection of electrical components making up an off-grid power supply system. There are also no verified algorithms for the control of the operation of an off-grid system being an alternative source of power supply.

The structure of a SDHN requires transition from district heating and power grid networks being traditionally independent to systems which are actively coupled. The district heating network thus has to be increasingly co-ordinated with the power grid. The expected outcome is a smart system integrating industries that have up till now been independent [2]. The authors of [12] indicate that SESs will fulfil an important role in implementing sustainable energy systems. A method of technical assessment of actively coupled district heating and power grid networks is proposed in [13].

The processes of integration and optimization of multiple energy networks (electricity grid, district heating grid, gas grid) are important issues in the building industry as well. This will help to increase the flexibility of future SESs that also use renewable energy [14].

The need to construct a SDHN contributed to the construction of the first off-grid system supplying power to a district heating chamber using

a turbine-based pressure controller (TPC) [15]. The turbine was installed on a pipeline belonging to the Municipal Heat Supply Company in Krakow. This paper presents the results of measurements performed during the operation of the first district heating chamber supplied with electricity by an off-grid power supply system. As indicated by the literature survey, this issue has not been analysed yet.

## 2 Technological description of the modernized district heating chamber

The off-grid power supply system located in the heating chamber of the Municipal Heat Supply Company in Krakow (Fig. 1) is the facility for the testing and analysis of the off-grid system operation. The district heating chamber (Fig. 2) was retrofitted to satisfy the needs of the tested off-grid power supply system. It was equipped with a TPC mounted on the pipeline. The turbine drives the generator. The main turbine and generator parameters are shown in Tables 1 and 2, respectively.

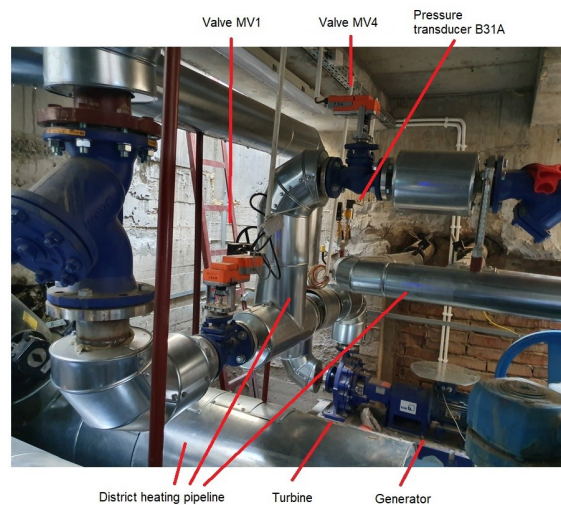

Figure 1: Fragment of the system in the district heating chamber.

The system located in the district heating chamber was extended by a bypass of the main return pipeline (DN 350). The bypass has the DN 250 diameter and branches into three pipelines:

- DN 100 pipeline, on which the turbine is located along with the generator and the MV1 valve,
- DN 100 pipeline, on which the MV2 valve is located,
- DN 250 pipeline, which is equipped with the MV3 valve.

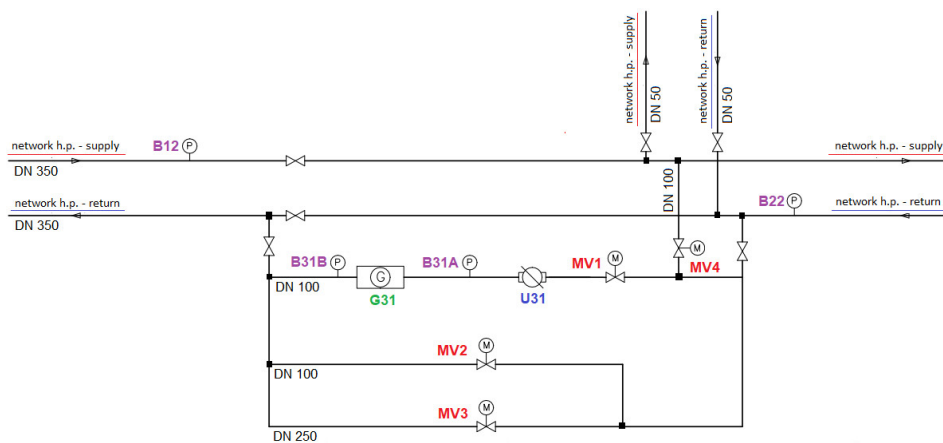

Figure 2: Flowchart of the district heating chamber: G31– generator with the turbine; MV1, MV2, MV3, MV4 – valves; U31 – flowmeter; B12, B22, B31A, B31B – pressure transducers.

Table 1: Turbine parameters.

Type	Etanorm 32-250
Capacity	19 m <sup>3</sup> /h
Delivery head	30 m
Rotational speed	1020 min <sup>-1</sup>

Table 2: Generator parameters.

Type	GV 100L8
Rated power	2 kVA
Rated voltage	28 V
Rated current	41.9 A
Rotational speed	1020 min <sup>-1</sup>
Frequency	68 Hz

To protect the off-grid power supply system against too low a flow rate of the heating medium driving the turbine, a DN 100 pipe was added to connect the supply and the return of the district heating network. The pipe connects the main feed pipeline (DN 350) to the DN 100 pipeline on which the turbine is installed. The medium flow through this connection is opened when the turbine is not operating (due to a small flow on the bypass) and at the risk of discharging the accumulators.

The pipeline in the district heating chamber is fitted with four pressure transducers (B12, B22, B31A, B31B), a flowmeter (U31) and four electrically driven control valves (MV1, MV2, MV3, MV4). These elements are powered by the off-grid supply system. The B12 pressure transducer measures the pressure on the main DN 350 feed pipeline, transducer B22 is used to measure the pressure on the main DN 350 return pipeline of the district heating network, while transducers B31A and B31B, respectively, measure the pressure upstream and downstream of the turbine. Flow meter U31 is used to measure the heating medium volume flow rate through the turbine. The task of valves MV1, MV2 and MV3 is to maintain the set value of the pressure in the return pipeline. Valves MV2, and MV3 maintain the set disposition and do not allow the return pressure B22 to be exceeded. Valve MV1 determines the appropriate operating point of the turbine. The medium flowing through valve MV1 drives the turbine located after it (G31). Valve MV4 operates only if a threat arises of complete discharge of the accumulators and no energy production by the generator due to too low a flow through the turbine. The MV4 valve is only opened for emergency charging of the accumulators.

The reason for installing the turbine on the bypass of the return pipeline was the medium lower temperature. The assumed mass flow rate through the chamber totals 97.22 kg/s in the winter period and 5.56 kg/s in summer. The main DN 350 return pipeline is closed and the entire heating medium flows through valves MV1, MV2 and MV3, i.e. through the bypass created during the chamber modernization.

### 3 Description of the tested facility electric system

The tested facility electric system (Fig. 3) includes the system of the electricity generator, the system of the valve drives, the system of the dewatering pump, the system of the cabinets with the control and measuring ap-

paratus and the lighting system. Measurements of the following quantities are performed on the off-grid power supply system: pressure, the medium volume flow rate through the turbine, the desired degrees of opening of the valves along with their actual positions, the voltage coming out of the generator after passing through the bridge rectifier, and the voltage supplying the equipment through the off-grid system. Trend logs are created for the measured quantities for data archiving.

The analysed off-grid power supply electric system (Fig. 3) is built based on an alternating current (AC) generator with voltage in the range of 24–28 V, driven by a water turbine mounted on the return pipeline of the district heating network. The supply from the electric current generator is fed to the controller through an alternating current/direct current (AC/DC) system. The system was built using the maximum power point tracking (MPPT) solar charge controller intended for off-grid photovoltaic (PV) systems, where voltage is obtained from PV panels. Two in-series configured 12 V 24 Ah accumulators are connected to the charge controller. The system is equipped with an accumulator protection module which ensures continuity of the 24 V DC supply and appropriate control of the charging of the accumulators. The maximum consumption power of the devices installed in the chamber, i.e. the electric drives of the valves, the dewatering pump,

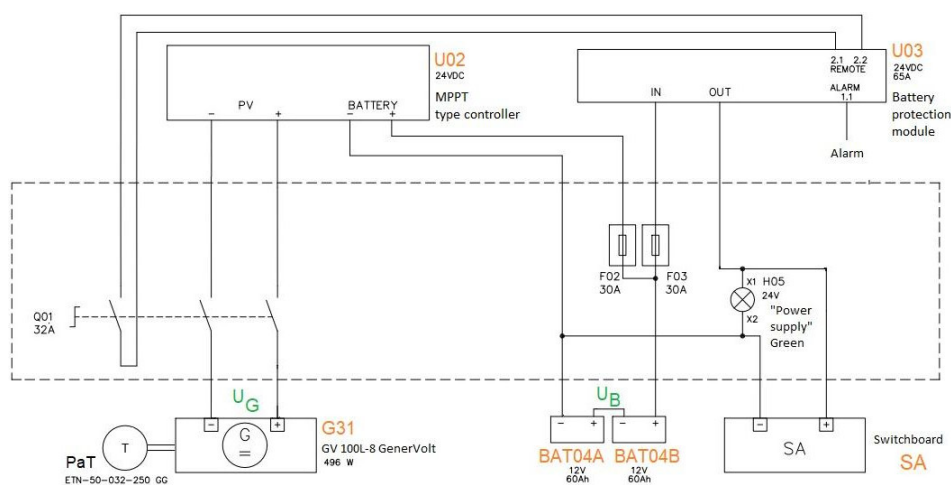

Figure 3: Diagram of the electric system of the generator connection to the controller: G31 – turbine with generator, U02 – MPPT controller, U03 – accumulator protection module, BAT04A, BAT04B – accumulators, SA – switchgear, Q01 – circuit breaker, F02, F03 – fuses, H05 – lamp.

the chamber lighting and the control system, totals 440 W at the supply voltage of 24 V DC.

### 3.1 Characteristics of the electric system elements

The off-grid power supply system consists of two main parts: the generation-storage and the power-receiving components. The generation-storage section includes a synchronous generator with permanent magnets, a charge controller, an accumulator protection module, and accumulators. The power-receiving part encompasses valve drives, a dewatering pump, a lighting system, and electrical cabinets.

A charge controller with the MPPT function is integrated into the off-grid system. The MPPT function continuously monitors the voltage and current intensity generated by the generator (at the controller input). Unlike conventional pulse width modulation (PWM) controllers, the MPPT controller can harness the maximum power produced by the generator. This maximizes the efficiency of energy utilization for charging the accumulators and powering other devices. The charge controller used in the system is designed with a maximum open-circuit voltage of 100 V, a rated charging current of 50 A, an accumulator voltage of 24 V, and a nominal power output of 1400 W at this voltage. The operating temperature range extends from  $-30^{\circ}\text{C}$  to  $+60^{\circ}\text{C}$ . To ensure safety, the off-grid system adheres to safe DC voltage parameters. Safe voltage refers to a voltage level that does not pose a risk to human health or life. Considering that the heating chamber can be classified as a wet environment, the safe voltage threshold is set at 30 V DC.

The installed accumulator protection module serves the dual purpose of preventing the accumulators from complete discharge, which could potentially damage them, and safeguarding them against a power drop below the level required for the engine to start. The accumulator protection function operates by disconnecting the accumulators from less critical power consumers. This module automatically detects the system voltage and provides overvoltage protection to prevent damage to power receivers. Additionally, it includes an alarm system that notifies users when the accumulator voltage falls too low. The initial off-grid system installed in the district heating chamber was constructed using two 12 V 60 Ah gel accumulators connected in series to store electricity.

Below, you will find an overview of the analysed operational parameters of the off-grid power supply system during real chamber operations.



### 3.2 Quantities measured in the district heating chamber

The quantities measured in the off-grid power supply system in the district heating chamber are provided at the beginning of Section 3 above. Pressure is measured using pressure transducers, where the measuring element is a piezoresistive silicon sensor, separated from the fluid by a diaphragm and a selected manometric liquid. The pressure transducer’s measuring range is from 0 to 2.5 MPa, and the output signal falls within the range of 4–20 mA. The intrinsic error of such transducers amounts to  $\pm 0.1\%$ . The medium volume flow rate through the turbine is measured using an Axonic ultrasonic flow transducer with a measuring range of 0.1 m<sup>3</sup>/h to 55 m<sup>3</sup>/h and Class 2 accuracy, compliant with the PN-EN 1434 standard. The positioning tolerance of the valves installed in the chamber is  $\pm 5\%$ . Voltage is measured using MB-1U-1 voltage transducers [16], which have a maximum measurement error of 0.5%, with a processing error totaling  $\pm 0.5\%$ .

### 3.3 Archiving of measurement data

All measured quantities are systematically archived in the supervisory control and data acquisition (SCADA) system. Additionally, a synoptic diagram of the district heating chamber has been created in the system (Fig. 4).

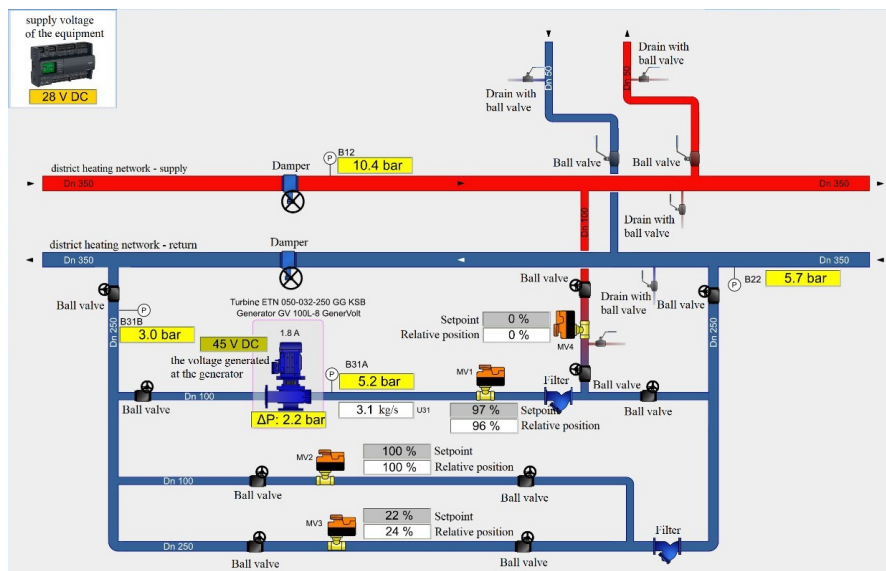

Figure 4: District heating chamber synoptic diagram in the SCADA system.

This diagram allows for the online tracking of various parameters related to the chamber's operation.

## 4 Measurement results and their analysis

The operation of the off-grid power supply system during the heating season is shown in Figs. 6, 8, 10, and 12, while Figs. 5, 7, 9, and 11 illustrate operation beyond the heating season. Figures 5–11 show the 24-hour measurement series at one-minute intervals, while Fig. 12 represents the 24-hour measurement series at five-minute intervals. Figures 5 and 6 show the

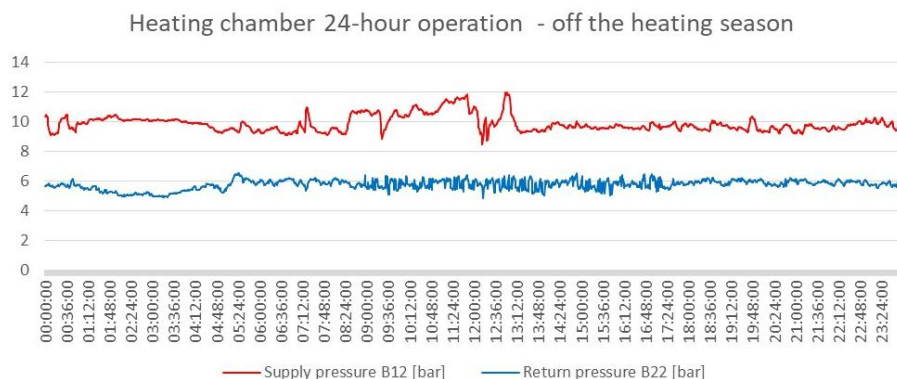

Figure 5: Supply and return pressure values of the district heating network main pipeline in the chamber – off the heating season.

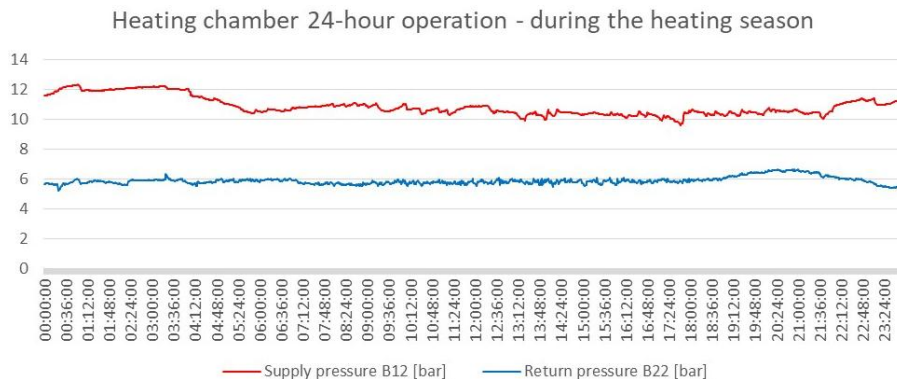

Figure 6: Supply and return pressure values of the district heating network main pipeline in the chamber – during the heating season.

supply and return pressures of the district heating network main pipeline. The pressure on the supply beyond the heating season (Fig. 5) oscillates around the value of 9.5 bar, whereas during the heating season (Fig. 6) it is between 10 and 12 bar. It can be observed that both the supply and the return pipeline of the district heating network operate with greater stability during the heating season.

The values shown in Figs. 7 and 8 represent the pressures upstream and downstream of the TPC on the return pipeline, beyond and during the heating season, respectively. The pressure upstream of the turbine both during and beyond the heating season totals about 5.5 bar. More frequent

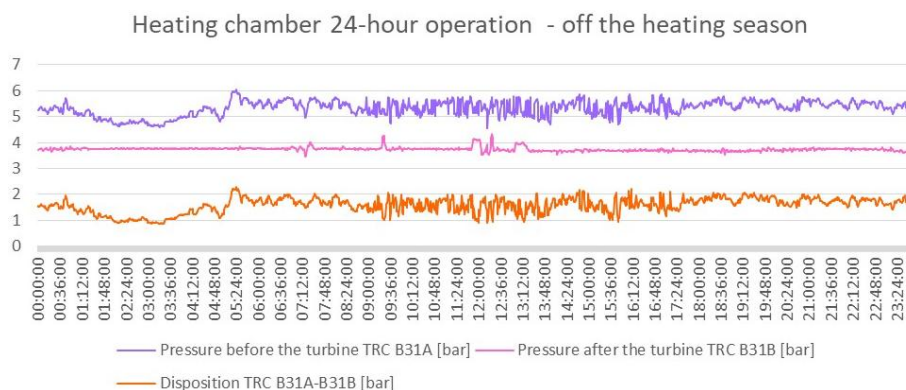

Figure 7: Pressure changes upstream and downstream of turbine, and disposition in the heating chamber (off-heating season).

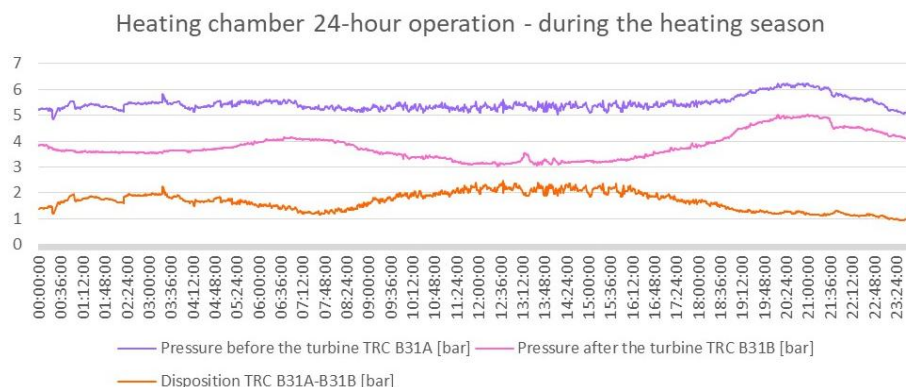

Figure 8: Pressure changes upstream and downstream of turbine, and disposition in the heating chamber (heating season).

and larger fluctuations in the pipeline pressure are visible off the heating season compared to the network operation in the heating season. Off the heating season, the district heating network supplies the heating medium mainly to the domestic hot water (DHW) system. The discontinuous nature of the operation of the domestic hot water system can cause pressure fluctuations in the district heating network off the heating season. The pressure downstream of the turbine beyond the heating season is more stable and oscillates around 3.8 bar (Fig. 7). During the heating season, the pressure downstream of the turbine also looks stable (Fig. 8). However, mild changes from about 3 bar to about 5 bar can be seen over a period of 5 h of operation. The so-called disposition, i.e. the difference between the pressure value upstream and downstream of the turbine, both in and beyond the heating season, varies between 0.9 bar and 2.2 bar.

Figures 9 and 10 show the curves illustrating changes in the heating medium volume flow rate through the turbine, the history of changes in the generator output voltage (after passing through the bridge rectifier) and in the accumulator voltage beyond and in the heating season, respectively.

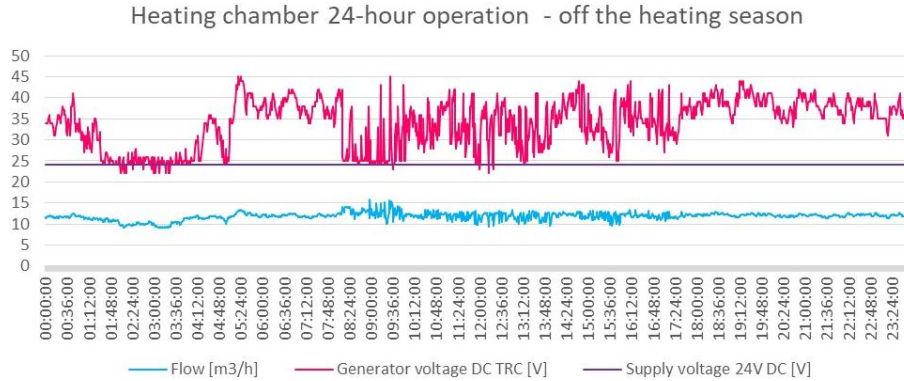

Figure 9: Turbine flow rate, generator voltage, and accumulator supply voltage (off-heating season).

The voltage at the accumulator output supplies the receivers included in the equipment of the district heating chamber and being a part of the off-grid power supply system. It follows from the analysis of the figures that the accumulator voltage beyond the heating season is 24 V DC (Fig. 9), while during the heating season it is 28 V DC (Fig. 10). This is a correct range of changes in the value of the device supply voltage, which is maintained by the MPPT controller. The voltage value at the generator output beyond

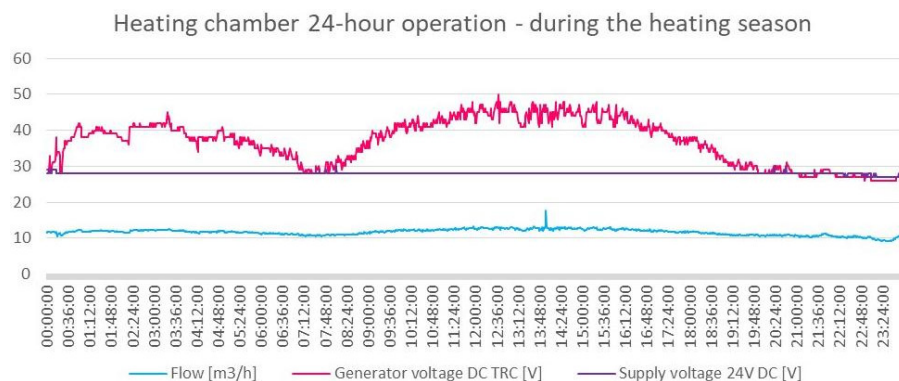

Figure 10: Turbine flow rate, generator voltage, and accumulator supply voltage (heating season).

the heating season varies strongly and ranges from 23 V to 40 V DC, with occasional measurement results between 40 V and 45 V DC (Fig. 9). During the heating season, on the other hand, the generator voltage is characterized by slightly more stable values, but in a higher range of values from about 30 V to about 48 V DC (Fig. 10). The fluctuations in the generator output voltage are caused by fluctuations in the volume flow rate and pressure of water in the district heating network. Even a slight change in these parameters involves a change in generated voltage, which can clearly be seen especially in the case of changes in the water volume flow rate. In the range of about 9 m<sup>3</sup>/h the water volume flow rate results in the generation of voltage of about 25 V DC. An increase in this quantity to about 12 m<sup>3</sup>/h translates into a much higher voltage, oscillating around 48 V DC.

The next two figures (Figs. 11 and 12) present the operation of valves under real conditions of the chamber operation. It is very useful to take advantage of the capability of the actuators to provide a feedback signal representing the valve actual position. By comparing the set value to the value from the positioner, it is possible to detect an emergency condition of the network. Such a condition can be seen in the part of Fig. 12 marked with the letter A, when, for example, a foreign object not captured by the filter gets under the valve and blocks the actuator operation. Beyond the heating season (Fig. 11), the MV3 valve is mostly in the closed position, with minor adjustments made within a 24-hour cycle. However, it plays a much bigger part in the regulation of the network operation during the heating season. Both off and during the heating season valves MV1 and MV2 are usually in the open position.

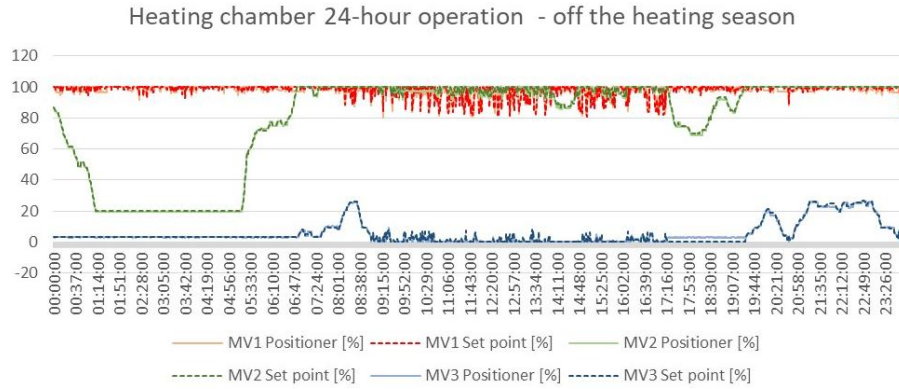

Figure 11: Valve set point and positioner (off-heating season).

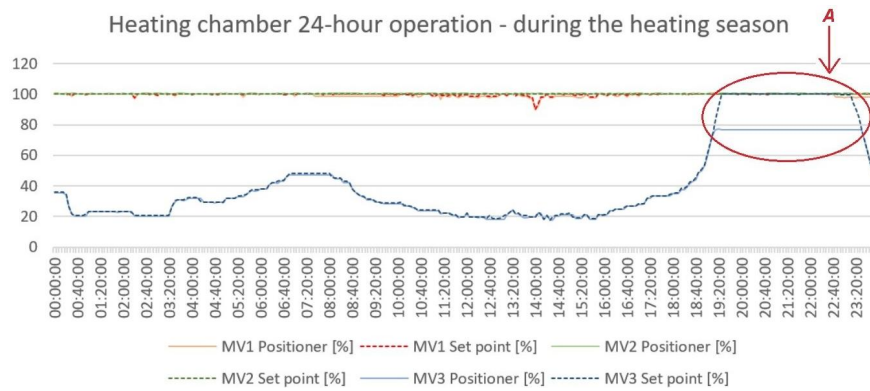

Figure 12: Valve set point and positioner in the district heating chamber (heating season).

## 5 Conclusions

The conducted analyses of the off-grid power supply of the district heating chamber show how much the voltage generated by the permanent magnet synchronous generator is affected by the flow rate of the medium through the turbine. The biggest problem is the high voltage values at the generator output and their considerable variability. This raises the question of where the problem lies. The solution may be selection of a turbine with parameters more suited to the operating conditions of the district heating network. On the other hand, the problem solution can just as well be found on the generator side. Measurements carried out in different periods of the district heating network operation (in and beyond the heating season) provide a lot



of information that should help in further works aiming to improve off-grid power supply.

The result of the work on the off-grid supply of the district heating chamber is local power generation. It enables visualisation of district heating network parameters at a given point and its control. It has been observed that the equipment selection (such as a turbine and generator) for an off-grid power system requires an individual approach. Namely, it is necessary to take into account the operating parameters of the grid at the off-grid location and to determine the electricity demand of the equipment supplied by the off-grid system.

Off-grid electricity generation to supply the district heating network facilities, such as heating chambers in the first place, offers great opportunities for the development of district heating. The off-grid power supply technology will not only enable but also speed up the development of smart district heating networks.

*Received 31 May 2023*

## References

- [1] Turski M., Sekret R.: *The need to reorganize district heating systems in the light of changes taking place in the building sector*. Rynek Energii **119**(2015), 4, 27–34 (in Polish).
- [2] Joniec W.: *District heating on the way to 5G generation*. Rynek Instalacyjny (2022), 3, 36–38 (in Polish).
- [3] EU H2020 FLEXYNETS Project: Fifth Generation, Low Temperature, High Exergy, District Heating and Cooling Networks, 2015.
- [4] Calise F., Liberato Cappiello F., Cimmino L., Dentice d'Accadia M., Vicidomini M.: *Optimal design of a 5th generation district heating and cooling network based on seawater heat pumps*. Energ. Convers. Manage. **267**(2022), 115912.
- [5] Grzebielec A., Rusowicz A., Jaworski M., Laskowski R.: *Possibility of using adsorption refrigeration unit in district heating network*. Arch. Thermodyn. **36**(2015), 3, 15–24.
- [6] Frotscher O., Oppelt T., Urbanrek T., Otto S., Heinrich I. Schmidt A., Göschel T., Uhlig U., Frey H.: *Software-in-the-loop-simulation of a district heating system as test environment for a sophisticated operating software*. In Proc. 9th Int. Conf. on Simulation and Modeling Methodologies, Technologies and Applications – SIMULTECH, Prague, 2019, 223–230.
- [7] Bujalski M., Madejski P., Fuzowski K.: *Day-ahead heat load forecasting during the off-season in the district heating system using generalized additive model*. Energ. Buildings **278**(2023), 112630.

- [8] Leśko M., Bujalski W.: *Modeling of district heating networks for the purpose of operational optimization with thermal energy storage*. Arch. Thermodyn. **38**(2017), 4, 139–163.
- [9] Lan T., Strunz K.: *Droop control for district heating networks: Solution for temperature control of multi-energy system with renewable power supply*. Int. J. Electr. Power Energ. Syst. **146**(2023), 108663.
- [10] Lindgren J.: *Numerical modelling of district heating networks*. MSc thesis, Umeå University, Umeå 2017.
- [11] Rzewuski M.: *On-grid, off-grid and hybrid installations*. Automatyka B2B (2021) (in Polish). <https://automatykab2b.pl/fotowoltaika/55360-instalacje-on-grid-off-grid-i-hybrydowe> (accessed 8 Dec. 2022).
- [12] Lund H., Østergaard P.A., Connolly D., Mathiesen B.V.: *Smart energy and smart energy systems*. Energy **137**(2017), 556–565.
- [13] Leitner B., Widl E., Gawlik W., Hofmann R.: *A method for technical assessment of power-to-heat use cases to couple local district heating and electrical distribution grids*. Energy **182**(2019), 729–738.
- [14] Zhang Y., Campana P.E., Yang Y., Stridh B., Lundblad A., Yan J.: *Energy flexibility from the consumer: Integrating local electricity and heat supplies in a building*. Applied Energy **223**(2018) 430–442.
- [15] Mazurek M., Piękoś M.: *New controllers based on water turbines – recovery of mechanical energy from mains water*. Polski Instalator (2017) (in Polish). <https://www.polskiinstalator.com.pl/artykuly/doradca-energetyczny/2065-nowe-regulatory-wzorowane-na-turbinach-wodnych-%E2%80%93-odzysk-energii-mechanicznej-z-wody-sieciowej> (accessed 8 Nov. 2022).
- [16] <https://www.fif.com.pl/pl/przetworniki-pomiarowe-moduly-rozszerzen/421-przetwornik-napiecia-mb-1u-1.html> (accessed 15 Jan. 2023).