

The effect of the internal reheat application on the efficiency of the 900 MW ultra-supercritical coal-fired power unit

HENRYK ŁUKOWICZ*
SŁAWOMIR DYKAS
KATARZYNA STĘPCZYŃSKA
SEBASTIAN RULIK

Silesian University of Technology, Institute of Power Engineering
and Turbomachinery, ul. Konarskiego 18, 44-100 Gliwice, Poland

Abstract The paper presents a thermal-economic analysis of a 900 MW coal-fired power unit for ultra-supercritical parameters with internal steam reheat. The subject of the study was the cycle proposed as the “initial thermal cycle structure” during the completion of the project “Advanced Technologies for Energy Generation” with the steam parameters of 650/670 °C /30 MPa. Two configurations of internal reheat were analysed: with a four- and seven-section exchanger. The effect of reheat on the operation of the power unit under a partial load was also analysed, and preliminary calculations of the heat exchange area of the internal reheat were made.

Keywords: Internal reheat; Ultra-supercritical coal-fired power units; Electricity generation efficiency

1 Introduction

The increase in steam parameters is definitely the main source of improvement in the power unit efficiency. However, a substantial rise in the temperature of steam, especially reheated steam, increases the problem of the

*Corresponding author. E-mail address: henryk.lukowicz@polsl.pl

difference in the temperature (of bleed steam and saturation) in feedwater heaters. This causes additional material and thermodynamic problems because with the rise in the mean difference in the temperature of the heat-exchanging agents, the exergy losses rise too, which leads to a reduction in the process effectiveness, and to an increase in the heating steam consumption. Therefore, the improvement in the operation of regenerative systems becomes a vital issue for ultra-supercritical power units in order to reduce exergy losses. To avoid this problem, in cycles with steam parameters of 600/620 °C, a special system of cross-feeding is often used, with bleed steam of the high pressure regenerative heaters. Another solution is to use the so-called internal steam reheat.

The idea of internal reheat consists in expansion of the configuration by additional heat exchangers introduced between the regenerative system and the turbine bleeds. In a conventional configuration, the steam from the turbine bleeds goes directly into regenerative exchangers. In the proposed solution, the bleed steam is cooled before it is introduced into the feedwater heater. The bleed steam heats up the outlet steam from the intermediate pressure part of the turbine which, after being heated in an internal reheater, is directed to the low pressure part of the turbine. The effects are [2]:

- an increase in enthalpy fall in the low pressure (LP) part of the turbine,
- an increase in the steam dryness factor at the turbine outlet and consequently a reduction in the losses of the wet steam flow through the turbine,
- a decrease in the steam mass flow at the outlet of the LP part of the turbine and a fall in the amount of heat given up in the condenser.

2 Analysis of selected internal reheat configurations

The aim of the analysis was to determine the effect of the internal reheat application on the basic operation indices of a modern supercritical power unit. Within the presented study two kinds of analyses were performed: a thermodynamic one with the use of the Gate Cycle commercial code and an economic one with the use of in-house software. The Gate Cycle software is an application which allows a design analysis of new and conceptual

systems (on-design mode), or an analysis of a selected cycle under variable operation conditions (off-design mode).

2.1 The 900 MW coal-fired power unit for ultra-supercritical parameters

A 900 MW coal-fired power unit for ultra-supercritical parameters was adopted for the considerations. The cycle has a four-stage low pressure regeneration (LPH1–LPH4) and a three-stage high pressure regeneration (HPH1–HPH3) plus a steam desuperheater (DS) — Fig. 1. The basic pa-

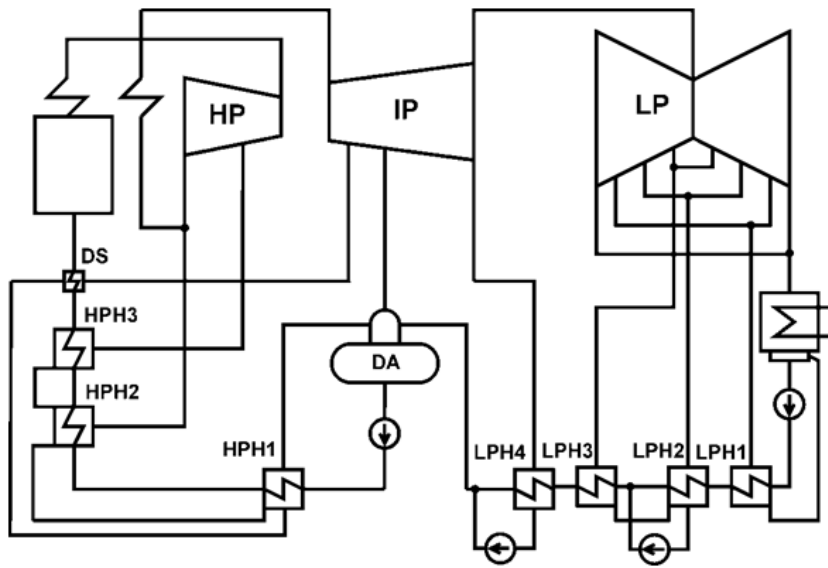

Figure 1. Diagram of the 900 MW power unit: HP, IP, LP – high, intermediate and low pressure part of large steam turbine, respectively; DS – steam desuperheater, DA – deaerator, LPH1–LPH4 – low pressure exchanger; HPH1–HPH3 – high pressure exchanger.

rameters of the cycle are listed in Tab. 1. The presented values of the internal efficiency of the low pressure part stage groups are: $\eta_{iLP1} = 85\%$ for the first three stage groups and $\eta_{iLP2} = 80\%$ for the last stage group. In the determination of the last stage group efficiency, the loss of the wet steam flow was omitted. Figure 2 shows the chart of bleed steam temperatures and the saturation temperature in individual exchangers. For exchanger HPH1, the difference between these temperatures is the highest and reaches 350 °C, but owing to the introduction of a steam desuperheater into the cycle, the

bleed steam temperature before the exchanger is lower than at the bleed and equals 395 °C. The basic indices of the power unit operation are listed in Tab. 2. The steam dryness factor at the condenser inlet is $X = 93.5\%$.

Table 1. Basic parameters of the conceptual 900 MW power unit.

Live steam pressure	30 MPa
Live steam temperature	650 °C
Reheated steam pressure	6 MPa
Reheated steam temperature	670 °C
Pressure in the condenser	0.005 MPa
Feed water temperature	310 °C
Boiler efficiency (hard coal)	94.5%
Internal efficiency of the turbine stage groups	$\eta_{iHP} = 90\%$ $\eta_{iIP} = 92\%$ $\eta_{iLP1} = 85\%$ $\eta_{iLP2} = 80\%$

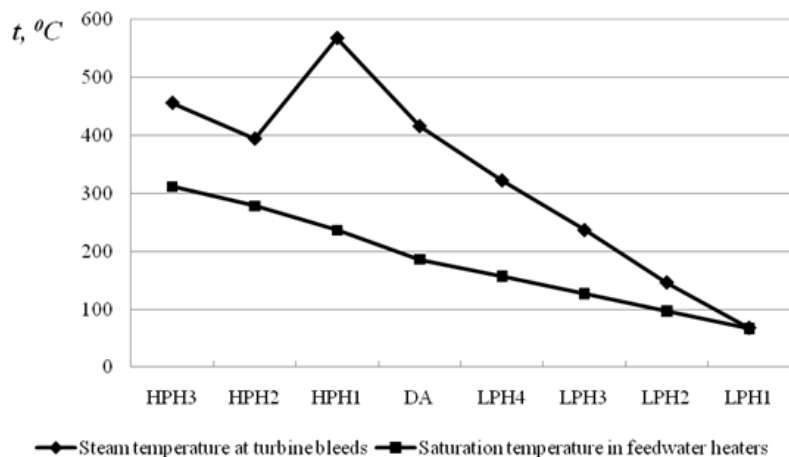

Figure 2. Steam temperature at turbine bleeds and saturation temperature in regenerative exchangers.

Table 2. Basic indices of the 900 MW power unit operation.

Gross electric power (at the generator terminals)	N_{elG}	900.0 MW
Net electric power (own needs index: $\delta=7.5\%$)	N_{elN}	832.5 MW
Cycle efficiency	$\eta_c = \frac{Q_{in} - Q_{out}}{Q_{in}}$	50.92%
Fuel chemical energy	Q_{en_ch}	1833 MW
Gross electricity generation efficiency (for hard coal)	$\eta_{elG} = \frac{N_{elG}}{Q_{en_ch}}$	49.1%
Net electricity generation efficiency	$\eta_{elN} = \frac{N_{elG}(1-\delta)}{Q_{en_ch}}$	45.42%
Internal power of the feed water pump	N_{FWP}	28.8 MW
Unit consumption of the fuel chemical energy (for hard coal)	$q = 3600 \frac{Q_{en_ch}}{N_{elG}}$	7322 kJ/kWh

2.2 Internal reheat configurations

The cycle of a 900 MW power unit without steam desuperheater was adopted for the analysis. The function of the desuperheater is taken over by internal reheat. Due to that, the pressure at the first bleed of the high pressure (HP) part of the turbine was increased so that the boiler feed water temperature would be identical as in the case of a cycle without reheat. It was assumed in the calculations that the parameters and the mass flow of live steam, the pressure in the condenser, the efficiency of individual stage groups of the turbine, and the boiler efficiency were identical as in the cycle without a reheat.

Two variants of the internal reheat configuration were considered. In Variant I (Fig. 3) the steam from the outlet from the intermediate part of the turbine is directed to a four-section membrane exchanger S1–S4, and then it flows into the low pressure part of the turbine. The heating agent is the bleed steam feeding the deaerator and heat exchangers HPH1–HPH3. In Variant II (Fig. 4) the steam collected from the low pressure part of the turbine is heated in a seven-section membrane exchanger. In sections S1 and S2 the bleed steam from the high pressure part of the turbine is cooled to the saturation temperature, and then it goes to sections CS2 and CS1.

The advantages of the improvement in the steam dryness factor in the

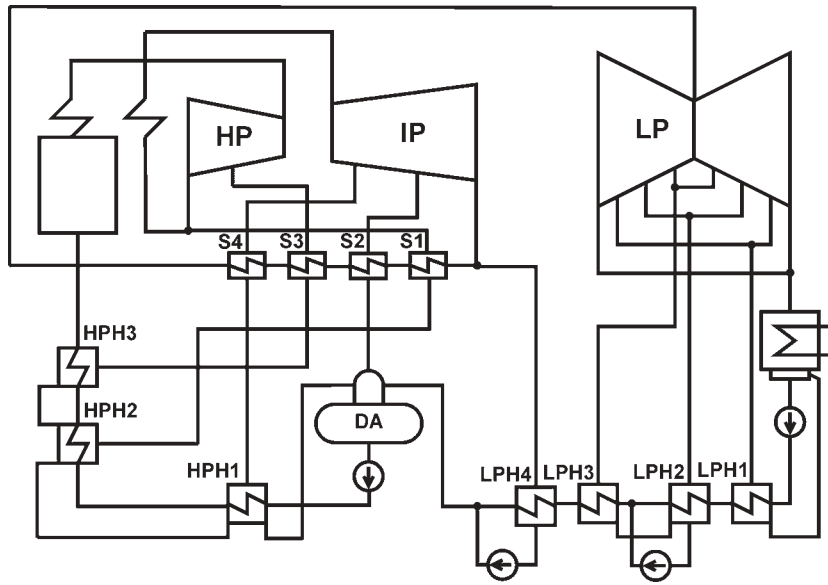

Figure 3. Diagram of the thermal cycle of the 900 MW power unit with a four-section internal reheat, S1–S4 – membrane exchanger (desuperheating section).

low pressure part of the turbine were also taken into account in the calculations. A higher dryness factor translates in this case into a better efficiency of the last stages of the LP part of the turbine, and prevents many operation-related problems. Calculations were conducted for the “initial” variant of the power unit and for the variants with internal reheat, with the loss of the wet steam flow both taken into account and omitted. The loss resulting from steam moisture content was calculated in two ways:

- according to Baumann equation [1]:

$$\eta_x = \bar{X} \eta, \quad (1)$$

$$\bar{X} = \frac{(x_1 + x_2)}{2}, \quad (2)$$

where:

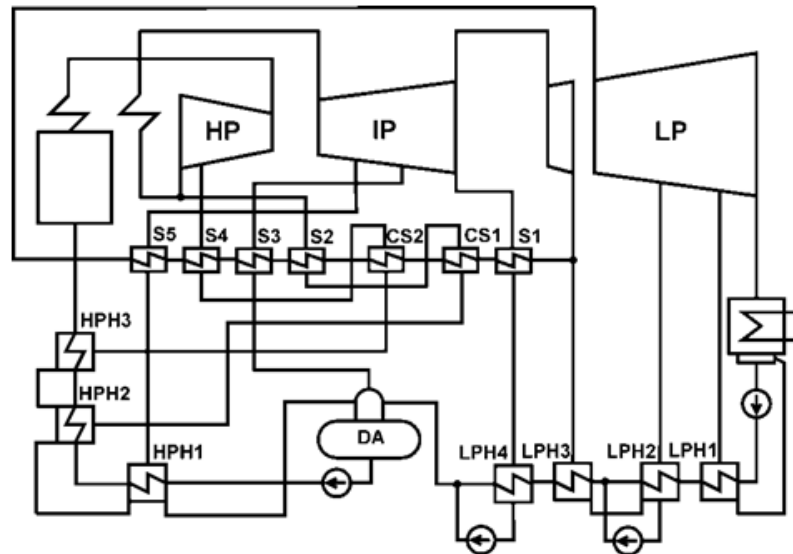

Figure 4. Diagram of the thermal cycle of the 900 MW power unit with a seven-section internal reheat, S1–S5 – membrane exchanger (desuperheating section), CS1–CS2 – membrane exchanger (condensing section).

- η_x – efficiency of the turbine stage group taking account of the impact of the steam dryness factor,
- η – efficiency of the turbine stage groups working in the area of superheated steam,
- \bar{X} – average dryness factor in the stage group,
- X_1 – dryness factor at the inlet to the stage group,
- X_2 – dryness factor at the outlet of the stage group,

- according to the chart (Fig. 5) of the dependence of the ratio η_x/η on the average mass content of moisture $1 - X$, developed on the basis of laboratory tests of low pressure turbines [5].

Figure 6 shows the bleed steam temperatures before regenerative exchangers and the saturation temperature in individual exchangers for the cycles with reheat and for the “initial” cycle. Table 3 presents the basic parameters of the power unit operation for two configurations with internal reheat.

The conducted thermodynamic analysis shows that the application of the internal reheat does not cause a significant improvement in the efficiency. For Variant II under consideration, the obtained efficiency of elec-

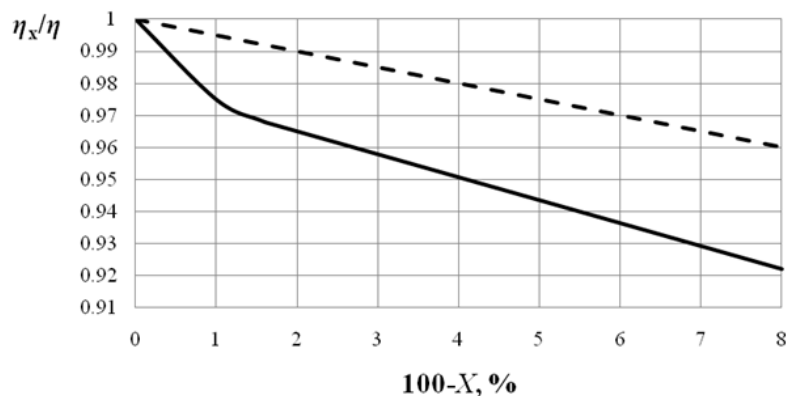

Figure 5. Chart of the dependence of the ratio on the average mass content $1-X$ (the loss calculated according to Baumann equation (1) is marked with a broken line).

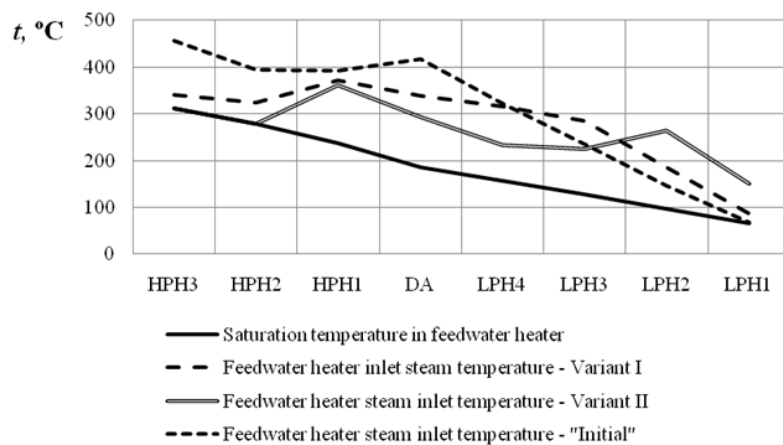

Figure 6. Bleed steam temperature and saturation temperature in individual regenerative exchangers.

tricity generation is even slightly lower than for the initial variant. A better efficiency was obtained only when the losses resulting from the moisture content in the last stages of the low pressure turbine were also taken into consideration. The use of internal reheat substantially raises the value of the dryness factor at the turbine outlet, which for the four-section reheat is 96.1%; for the seven-section exchanger it equals almost 100%. The increase in the efficiency, depending on the considered variant and on the ways to

Table 3. Basic parameters of the power unit operation with internal reheat compared to the “initial” power unit configuration.

	Parameter	“Initial” variant	Variant I	Variant II
Without losses of the wet steam flow	N_{elG}	900 MW	- 8.4 MW	- 20.3 MW
	η_{elG}	49.1%	+ 0.07%	- -0.04%
Loss calculated according to Baumann equation	N_{elG}	896.6 MW	- 6.4 MW	- 16.9 MW
	η_{elG}	48.91%	+ 0.18%	+ 0.15%
Loss calculated according to Fig. 5	N_{elG}	895.3 MW	- 6.2 MW	- 15.6 MW
	η_{elG}	48.84%	+ 0.19%	+ 0.22%

Table 4. Power capacities of the individual parts of the turbine, and the ratio of the steam mass flow collected from bleeds to the mass flow of live steam.

Turbine part	N_{elG} [MW]			$\frac{\dot{m}_b}{\dot{m}_l}$ [%]		
	“Initial”	Variant I	Variant II	“Initial”	Variant I	Variant II
HP	268.2	261.9	257.4	15.6	19.4	24.1
IP	349.5	335.6	321.1	13.8	13.3	12.6
LP	277.6	291.6	301.2	10.5	9.7	8.9
Total	895.3	889.1	879.7	39.9	42.4	45.6

determine losses resulting from the content of moisture, ranged from 0.15% to 0.22%. It should be noted that the application of internal reheat increases also the intake of bleed steam. Table 4 presents power capacities of the individual parts of the turbine, and the ratio of the bleed steam mass flow m_b to the mass flow of live steam m_l . The live steam mass flow was in this case a constant value. Depending on the considered internal reheat configuration, the increase in the bleed steam mass flow ranges from 2.5% to 5.7%. Therefore, assuming a constant live steam mass flow, the power obtained from the turbine set is lower. The fall in rated power can in this case reach more than 15 MW.

2.3 Area of the internal reheat exchangers and steam pressure losses

For the considered configurations of internal reheat exchangers, preliminary calculations of the heat exchange area were made. The calculations were based on the results obtained from thermal cycle modelling. The cross flow heat exchanger of the shell-and-tube type with finned tubes was adopted for the analysis. The choice of the type of the heat exchanger was determined by significant differences in the heat transfer coefficients between the agents exchanging heat, especially in the condensing sections of the internal reheater. The heating steam in the case under consideration flows inside the tubes of the heat exchanger. The structure was adopted according to [2]. Heat flux Q in the exchanger section was determined on the basis of the energy balance with the data obtained from the calculations of the cycle. Overall heat transfer coefficient k for finned tubes was calculated according to:

$$\frac{1}{k} = \frac{1}{\eta\alpha_1} + \frac{\beta_1}{\beta_2} \left(\frac{\delta}{\lambda} + \frac{1}{\alpha_2} \right), \quad (3)$$

where:

- α_1, α_2 – heat transfer coefficients on the inside and outside of the tubes,
- δ – thickness of the tube wall,
- λ – heat conductivity of the tube material,
- η – fin efficiency,
- β_1, β_2 – heat exchange area in a volume unit on the outside and inside of the tubes.

In the exchanger sections S which cool steam, the heat transfer coefficient was determined from the relation:

$$\text{Nu} = 0.023\text{Re}^{0.8}\text{Pr}^{0.33}, \quad (4)$$

where: Nu – Nusselt number, Re – Reynolds number, Pr – Prandtl number. The following relation was used for the condensing sections CS:

$$\text{Nu} = 0.023\text{Re}^{0.8}\text{Pr}^{0.4} \left[1 + 0.63 \left(\frac{\rho_w}{\rho_v} \right)^{0.67} \cdot X \right], \quad (5)$$

where: ρ_w, ρ_p – density of water and vapour, X – steam dryness factor.

Heat exchange area A was determined according to:

$$A = \frac{Q}{k\Delta t_m}, \quad (6)$$

where:

- Q – heat flux,
- k – heat coefficient,
- Δt_m – logarithmic temperature difference in the exchanger.

The total area of internal reheat exchangers was 7200 m² for Variant I (four-section exchanger) and 11100 m² for Variant II (seven-section exchanger).

Flow losses Δp on part of the cooling agent (reheated steam) were calculated according to [6]:

$$\Delta p = Eu \rho v^2, \quad (7)$$

$$Eu = 0.085m \left(\frac{h}{d}\right)^{0.3} \left(\frac{u}{d}\right)^{-0.58},$$

where:

- Eu – Euler number,
- ρ – steam density,
- v – steam mass flow velocity,
- m – number of tube rows in a bank,
- h – fin height,
- d – equivalent diameter,
- u – fin spacing.

Flow losses Δ on part of the heating agent (bleed steam) were calculated according to:

$$\Delta p = \lambda \frac{L}{d} \frac{v^2}{2} \rho, \quad (8)$$

where

- λ – linear resistance coefficient,
- L – tube length,
- d – inside tube diameter,
- v – steam mass flow velocity,
- ρ – steam density.

For Variant I the pressure loss on part of reheated steam in relation to the pressure at the inlet to the condenser was 0.7%, and for Variant II – 1%. Pressure losses on part of bleed steam varied, depending on the reheat section, and they were included within the range of 0.5–2%.

2.4 Power unit operation under a changing load

Analysis of the operation under a changing load was conducted for the “initial” configuration of the 900 MW power unit and for two variants with

internal reheat. The aim of the analysis was to determine the impact of a partial load of the power unit on its efficiency. It was assumed in the calculations that the values of internal efficiency of individual stage groups of the turbine and of the boiler efficiency were constant. Figure 7 presents the chart of the dependence of gross efficiency of electricity generation on the electric capacity of power unit. The obtained characteristics have a similar course. It should be noted, however, that as the load of the power unit decreases, the gross increase in efficiency obtained owing to the application of internal reheat becomes smaller and smaller.

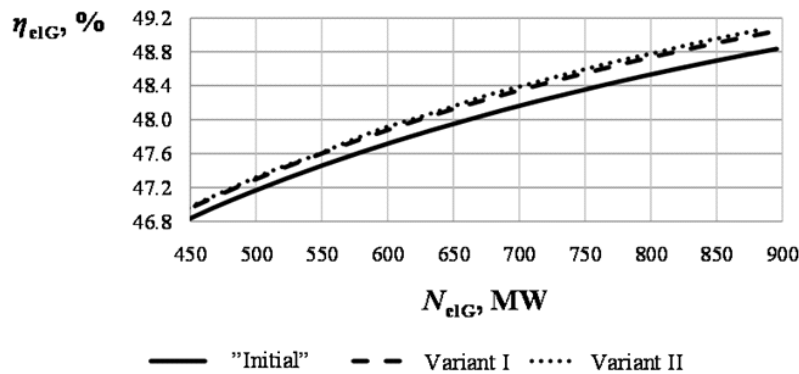

Figure 7. The chart of the dependence of the gross efficiency of electricity generation on the gross electric capacity for a cycle with and without internal reheat.

3 Analysis of economic efficiency

The economic analysis of the considered ultra-supercritical power unit variants with internal reheat was based on the net present value (*NPV*) method. The net present value is defined by the following expression:

$$NPV = \sum_{\tau=1}^{\tau=N} \frac{CF_{\tau}}{(1+r)^{\tau}}, \quad (9)$$

where:

- CF_{τ} – cash flows in time τ ,
- r – discount rate,

- τ – next year of consideration from the commencement of the cycle construction ($\tau = 1$ – the year when the construction was started),
- N – power unit service life.

Discount rate r is calculated from the following relation:

$$r = r_k(1 - p_d)u_k + r_w(1 - u_k), \quad (10)$$

where:

- r_k – commercial credit rate,
- p_d – income tax,
- u_k – share of credit in the investment financing,
- r_w – return on equity.

Cash flows in time τ are defined by the following dependence:

$$CF_\tau = [-J + S_{el} - (K_{op} + P_d + K_{cwc}) + A + L]_\tau, \quad (11)$$

where:

- J – investment expenditures,
- S_{el} – revenues from the sale of electricity,
- K_{op} – operating costs,
- P_d – income tax,
- K_{cwc} – change in the working capital,
- A – depreciation,
- L – liquidation value.

The determination of the total investment expenditures was based on unit investment expenditures necessary to build 1 kW of electric power:

$$J = i_X N_{el}. \quad (12)$$

Revenues from the sale of electricity

$$S_{el} = \int_0^{\tau_{el}} (1 - \delta_c) N_{el} C_{el} d\tau_{el}, \quad (13)$$

where:

- N_{el} – power unit gross electric power,
- C_{el} – average selling price of electricity,
- τ_{el} – total annual operation time of the power unit,
- δ – the power unit own needs index.

Operating costs:

$$K_{op} = K_f + K_o + K_{ps} + K_e + K_r + K_u + A_k + A, \quad (14)$$

where:

- K_f – fuel costs,
- K_o, K_r, K_u – servicing, maintenance and repair costs,
- K_{ps} – costs related to other raw materials,
- K_e – other operating costs (including environmental charges),
- A_k – excise tax cost,
- A – depreciation.

The subject of the economic analysis was the presented 900 MW ultra-supercritical power unit with internal reheat. The application of a smaller four-section exchanger (Variant I) and a bigger, seven-section one (Variant II) was considered. Table 5 presents the basic data assumed during the economic analysis. The adopted discount rate was determined from the relation (10). It was assumed that the service life of the power unit was 20 years. The construction of the power unit was spread over 4 years, and the involvement of investment means in each year was 10%, 25%, 35%, and 30%, respectively. The decommissioning value of the investment was omitted in the calculations of the *NPV*. Excise tax costs were not taken into consideration, either, due to the new laws which require that excise tax be paid not by electricity manufacturers but by its suppliers.

Additionally, it was assumed that the costs of repairs and insurance are constant and each year they are equal to 1% of the investment expenditures. In order to determine the investment expenditures, the average exchange rate of 1 US Dollar in the previous three months was assumed at 2.89 PLN. The economic analysis also included the costs of emissions of sulphur and nitrogen oxides, and carbon dioxide. Moreover, many extra fixed and variable costs were taken into account, such as the costs of disposal of solid combustion products, lime suspension costs or the cost of demineralised water. The basic operation indices of the power unit listed in Tab. 3 were adopted for the purposes of the economic analysis. Additionally, for all variants under consideration the own needs index was assumed as $\delta = 7.5\%$.

Table 6 presents the results of the economic analysis conducted for the initial variant and for the two concepts of the internal reheat application. The efficiency of electricity generation was in this case determined taking into account the loss resulting from moisture content according to Fig. 5. The performed calculations also take account of the CO₂ emissions charge of

Table 5. Basic data adopted for the economic analysis.

Annual operation time of a coal-fired power unit	8000 h
Average price of fuel (hard coal – 23 MJ/kg)	270 PLN/Mg
Price of electricity	220/320 PLN/MWh
Employment	0.4 person/MW
Unit payroll cost	6000
Depreciation rate	6%
Income tax rate	19%
Share of equity	20%
Own means interest rate	5.75%
Discount rate	6.33%
Commercial credit interest rate	8%
Commercial credit repayment period	10 years
Power unit service life	20 years
CO ₂ emissions charge price	150 PLN/Mg _{CO₂}

150 PLN/tonne_{CO₂}. In this case, to achieve the return on investment, it was necessary to raise the electricity selling price from 220 to 320 PLN/MWh. The unit investment expenditures were defined assuming that the investment *NPV* equalled zero, which means that these are maximum expenditures which, if exceeded, will cause that the investment will start making a loss. For the variants under consideration, both the efficiency of electricity generation and rated power were changeable values resulting from adopted assumptions.

Table 6. Comparison of the discussed power unit variants with internal reheat for *NPV* = 0.

Case under consideration	η_{elG} [%]	N_{elG} [MW]	Investment expenditures per unit	
			CO ₂ emissions charges omitted	CO ₂ emissions charges taken into consideration
			Selling price of electricity	Selling price of electricity
			220 PLN/kWh	320 PLN/kWh
			USD/kW / PLN/kW	USD/kW / PLN/kW
"Initial" variant	49.10	900.00	2168.6 / 6267	1905.0 / 5505
Variant I	49.29	896.60	2175.4 / 6287	1920.4 / 5550
Variant II	49.32	895.30	2176.6 / 6290	1922.7 / 5557

The value of the maximum unit investment expenditures in the case of an application of internal reheat with a four-section exchanger (Variant I) increases by approximately 6.9 USD/kW (20 PLN/kW) compared to the initial variant. The value for Variant II with a seven-section exchanger is 8 USD/kW (23 PLN/kW). Considering total expenditures at the assumed power capacity of 900 MW, the expenditures for internal reheat in Variant I may reach 6.2 million US Dollars (18.0 million PLN), and in Variant II – 7.2 million US Dollars (20.7 million PLN). An inclusion of the carbon dioxide emissions charges in the economic analysis significantly raises the possible increase in profitable investment expenditures related to the use of internal reheat. In such a case, the unit investment expenditures for Variant I may rise by 15.6 USD/kW (45 PLN/kW), and for Variant II – by 18.0 USD/kW (52 PLN/kW). In terms of the total investment expenditures, it gives 14 million US Dollars (40.5 million PLN) and 16.2 million US Dollars (46.8 million PLN), respectively. This means that the inclusion of extra costs related to the CO₂ emissions charges in the economic analysis produces over a twofold increase in the profitability of the solution under discussion.

An important stage in the economic analysis is also the appropriate estimate of additional investment expenditures related to the internal reheat application. Therefore, it was assumed that the unit cost of a heat exchanger was 9.7 USD/kg (28 PLN/kg). The price includes the cost of material, workmanship and installation. On the basis of the previously determined heat exchange area, this gives the amount of 1.3 million US Dollars (3.8 million PLN) for the four-section exchanger (Variant I), and 2.0 million US Dollars (5.8 million PLN) for the seven-section exchanger (Variant II). Comparing the potentially obtainable profits and the investment expenditures related to the internal reheat application, it can be concluded that the solution may be profitable. The profits in the considered 20-year period of return on investment vary from 4.9 million dollars (14.2 million PLN) to 14.2 million US Dollars (41 million PLN) with the carbon dioxide emissions charges additionally taken into consideration (Variant II).

It should be emphasised, however, that the determination of both the advantages resulting from the internal reheat application and the related additional costs is a complex task. It is due to the fact that the solution entails a change in the structure of the turbine itself, the costs of extra pipelines as well as those related to the increase in the area of installation of a large-size exchanger. Moreover, it is difficult to define the increase in

the efficiency of the low pressure turbine resulting from the higher dryness factor in cycles with internal reheat. Therefore, the decision whether or not to apply the presented solution should be preceded with a series of detailed analyses for a selected thermal cycle configuration.

4 Conclusions

The conducted analysis of the 900 MW coal-fired power unit for ultra-supercritical parameters with the internal steam reheat application showed the maximum increase in the power unit efficiency of the order of 0.2%. The difference between efficiency values obtained for the two considered variants of the internal reheater was slight. The application of internal reheat causes that the end of the steam expansion line is shifted to the area of higher values of the dryness factor — for the variant with the seven-section reheater, expansion line ends just beyond the saturation line. This results in an increase in the efficiency of the last turbine stages and in a decrease in the erosive action of steam on the flow system of the turbine. Despite the fact that in the variant with a seven-section reheater the outlet steam dryness factor is close to 100%, the fall in the power capacity of the HP part is so large that the application of a bigger number of exchangers does not give significant effects. The internal reheat application also entails an installation of a large-size exchange heater at the site of the power plant with the area of the order from several to fifteen or so thousand square meters. The heat exchange in such an exchanger occurs almost exclusively between reheated steam. This is why the heat transfer coefficients have relatively small values. Another important issue is the estimate of the value of the steam pressure loss, as this parameter has a significant impact on the efficiency of cycles with internal reheat.

The conducted comparative analysis of the "initial" cycle and of the cycle with applied internal reheat showed that as the load of the power unit decreased, the increase in the gross efficiency obtained owing to the internal reheat application decreased too.

The economic analysis proved that the solution under discussion could be profitable. For the considered 20-year period of return on investment, the profits vary from 4.9 million Dollars (14.2 million PLN) to 14.2 million US Dollars (41 million PLN) with the carbon dioxide emissions charges additionally taken into consideration (Variant II). It should be noted, however, that both the profits resulting from the internal reheat application and

the costs of this solution should be subjected to a very detailed thermal-economic analysis for each specific thermal cycle configuration.

Acknowledgements The results presented in this paper were obtained from research work co-financed by the Polish National Centre of Research and Development in the framework of Contract SP/E/1/67484/10 – Strategic Research Programme – Advanced technologies for energy generation: Development of a technology for highly efficient zero-emission coal-fired power units integrated with CO₂ capture.

Received 10 October 2011

References

- [1] CHMIELNIAK T.: *Thermodynamical cycles of turbines*. Wrocław 1988 (in Polish).
- [2] KRZYŚLAK P., CHMIELNIAK T.: *A concept of internal reheat and analysis of its thermodynamical and economical effectiveness*. In: *Supercritical Cycles for Coal-Fired Systems* (T. Chmielniak, A. Ziębik, eds.) Silesian University of Technology Publishers, Gliwice 2010 (in Polish).
- [3] KRZYŚLAK P.: *Efficiency of turbopower systems with and without internal reheat*. *Archiwum Energetyki (Archives of Energetics)* **XXI** (2002), 3/4, 57–69 (in Polish).
- [4] KUBSKI P.: *Influence of interstage internal reheat on efficiency of the power unit*. *Energetyka* **4**(2001), 189–193 (in Polish).
- [5] LOGAN E. JR., ROY R.: *Handbook of Turbomachinery*. 2005.
- [6] PIETROWSKI J. W., FASTOWSKI W. G.: *Contemporary high-efficiency heat exchangers*. Warsaw 1964 (in Polish).